

Description

High pressure gear pumps KP Duro Tec® for abrasive and poor lubricating fluids.

In the year 1990, KRACHT initiated the development of high pressure gear pumps for abrasive and poor lubricating fluids. Since then, this development has been subsequently improved.

The limit of applications of transfer gear pumps has been reached when the transfer medium does not have the required lubricity for a proper function of the pump and a high operating pressure is needed at the same time.

Such problematic fluids are for example silicates (sodium silicate), isocyanates and polyols with hard fillers as can be found in the PUR-technology.

Under air or humidity influence, crystallisation of these fluids occurs and aggravates the lack of lubricity.

First introduced in the year 1990 and since then well-proven in many different applications the Duro Tec® transfer gear pumps have been improved considerably by constructive measurements.

The most significant difference to the earlier model is that the gear (gear wheel and shafts) is now completely surrounded by SIC-doubleglend bearings. The gear is high-rigid protected against wear, taken the requirements regarding material, heat treatment, surface geometry into consideration when using this coating technology.

Highest demands have been fulfilled by our own manufacturing quality and the involved coating specialists.

The well-proven shaft sealing with sealing liquid between two rotary shaft lip-type seals to avoid crystallisation has been kept.

Construction

The construction of the pump is shown in the cross-section:

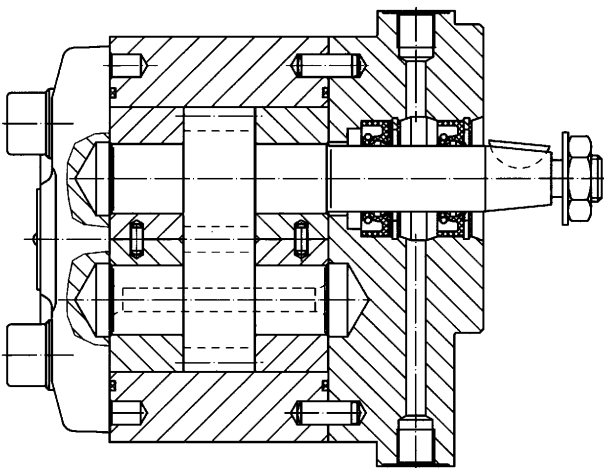

Depending on the medium to be transferred, operating pressures up to 150 bar are possible with driving speeds of about 1500 rpm.

The housing produced out of high-rigid spheroidal graphite iron takes up SIC-doubleglend bearings, in which the CVD-coated gear runs.

Solid body parts with a size $<50 \mu\text{m}$ and a hardness acc. to Vickers <2500 will be accepted in the transfer medium.

The main field of application for the new KP Duro Tec® pumps are mainly multi-component-systems in the PUR-technology.

Everywhere where standards pumps do not reach a satisfying lifetime, e.g. where polyols with hard fillers have to be handled, this pump offers a reliable alternative.

General Characteristics

Mounting:	Flange type
Pipe connection:	Flange (Threaded ports on request)
Direction of rotation:	clockwise (anticlockwise on request)
Mounting position:	optional

Operating Characteristics

Displacement:	$V_g = 5.5; 6.3; \mathbf{8}; \mathbf{11}; 16; 19; \mathbf{22} \text{ cm}^3$ (Preferred type series „ bold “ printed)
Operating pressure	Inlet port
	$p_{e \text{ min}} = -0.4 \text{ bar}$ $p_{e \text{ max}} = 5.0 \text{ bar FPM rotary shaft lip-type seal}$
	Outlet port
	$p_{e \text{ max}} = 150 \text{ bar (depending on transfer medium)}$
Speed	$n = \text{up to ... } 1500 \text{ rpm (depending on viscosity)}$
Viscosity:	$\nu = 20000 \text{ mm}^2/\text{s (higher viscosities on request)}$
Medium temperature:	$\vartheta_{\text{max}} = 150 \text{ }^\circ\text{C}$

Materials

Housing:	GGG 60
Doublegland bearing:	SIC HV2200
Gear:	CVD – TiC – TiCN – TiN coated HV4000
Sealing:	Double rotary shaft lip-type seal for sealing liquid
Efficiency:	Vol. efficiency 85 % at 100 bar, $n = 1000 \text{ rpm}$ with test medium HLP 46 at $20 \text{ }^\circ\text{C}$

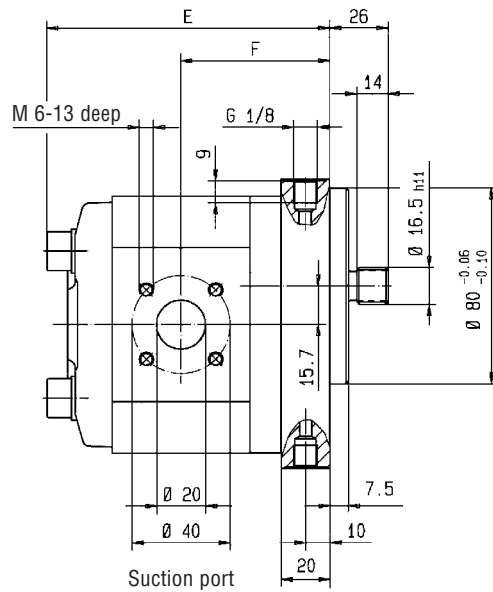

Shaft end:
 Involute spline B 17 x 14 DIN 5482
 but tooth thickness $s_w = 3.206$
 Addendum modification = + 0.6

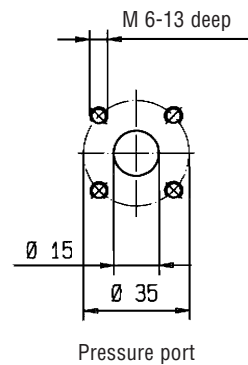
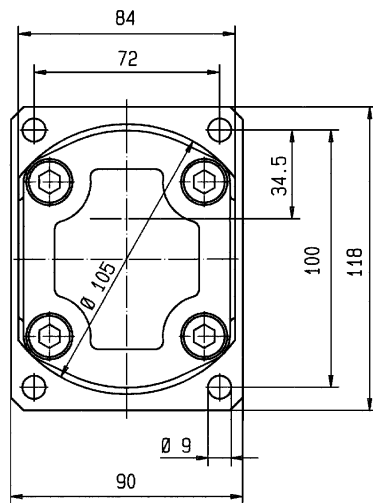

	Displacement nominal size						
	5.5	6.3	8	11	16	19	22
E	106.2	107.6	110.4	115.4	123.8	128.8	134.6
F	56.1	56.8	58.2	60.7	64.9	67.4	70.3

Type Key

