

Low Pressure Filter

Pi 150

Nominal pressure 10/25 bar (140/360 psi), nominal size up to 630

1. Features

High performance filters for modern hydraulic systems

- Provided for pipe installation
- Modular system
- Compact design
- Minimal pressure drop through optimal flow design
- Visual/electrical/electronic maintenance indicator
- Threaded connections
- Quality filters, easy to service
- Equipped with highly efficient glass fibre PS filter elements
- Beta rated elements according to ISO 16889 multipass test
- Elements with high differential pressure stability and dirt holding capacity
- Worldwide distribution



3. Separation grade characteristics

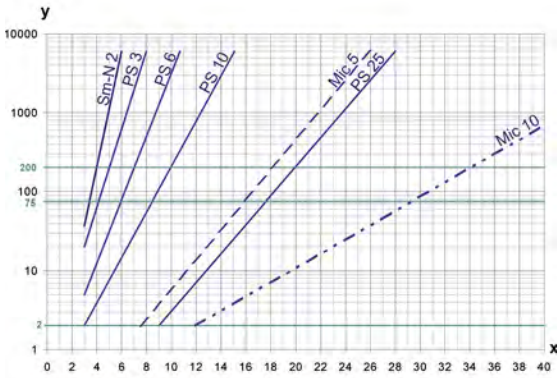

y = beta-value
x = particle size [μm]

determined by multipass tests (ISO 16889)
calibration according to ISO 11171 (NIST)

4. Filter performance data

measured according to ISO 16889 (multipass test)

PS elements with max. Δp 10 bar

Sm-N 2 elements with max. Δp 5 bar

Sm-N	2	$\beta_{4(C)}$	≥ 200
PS	3	$\beta_{5(C)}$	≥ 200
PS	6	$\beta_{7(C)}$	≥ 200
PS	10	$\beta_{10(C)}$	≥ 200
PS	25	$\beta_{20(C)}$	≥ 200

values guaranteed up to 10 bar differential pressure, Sm-N 2 elements up to 5 bar differential pressure

The filter element Sm-N 2 is an element with a very large dirt holding capacity, especially for bypass filtration.

5. Quality assurance

MAHLE filters and filter elements are produced according to the following international standards:

Norm	Designation
DIN ISO 2941	Hydraulic fluid power filter elements; verification of collapse/burst resistance
DIN ISO 2942	Hydraulic fluid power filter elements; verification of fabrication integrity
DIN ISO 2943	Hydraulic fluid power filter elements; verification of material compatibility with fluids
DIN ISO 3723	Hydraulic fluid power filter elements; method for end load test
DIN ISO 3724	Hydraulic fluid power filter elements; verification of flow fatigue characteristics
ISO 3968	Hydraulic fluid power filters; evaluation of pressure drop versus flow characteristics
ISO 10771.1	Fatigue pressure testing of metal containing envelopes in hydraulic fluid applications
ISO 16889	Hydraulic fluid power filters; multipass method for evaluation filtration performance of a filter element

6. Symbols

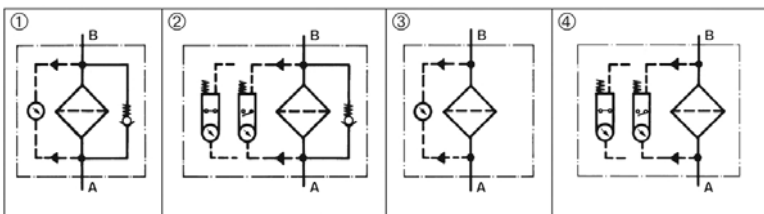

7. Order numbers

Example for ordering filters:

1. Housing design	2. Filter element
V = 400 l/min, bypass, electrical indication, nominal pressure 10 bar Type: Pi 1535 / 10-058 Order number: 77774631	PS 10 Type: 852 760 PS 10 Order number: 77774425

7.1 Housing design

Nominal size NG [l/min]	Order number	Type	Nominal pressure [bar]	①	②	③	④
				with bypass valve and visual indicator	with bypass valve and electrical indicator	with visual indicator	with electrical indicator
400	77774649	Pi 1535/10-057	10				
	77774631	Pi 1535/10-058					
	77804909	Pi 1535/10-068					
	77804917	Pi 1535/10-069					
	77955982	Pi 1535/25-057	25				
	77907892	Pi 1535/25-058					
630	77774623	Pi 1560/10-057	10				
	77774615	Pi 1560/10-058					
	77804941	Pi 1560/10-068					
	77804958	Pi 1560/10-069					
	77955990	Pi 1560/25-057	25				
	77970718	Pi 1560/25-058					

When filter with non bypass configuration is selected the collapse pressure of the element must not be exceeded.

7.2 Filter elements*

Nominal size NG [l/min]	Order number	Type	Filter material	max. Δp [bar]	Filter surface [cm ²]
400	77774458	852 760 Mic 5	Mic 5	5	23800
	77774441	852 760 Mic 10	Mic 10		23800
	77955859	852 760 Sm-N 2	Sm-N 2		16000
	77774433	852 760 PS 3	PS 3	10	14500
	78299042	852 760 PS 6	PS 6		14500
	77774425	852 760 PS 10	PS 10		14500
	77806565	852 760 PS 25	PS 25		14500
630	77774417	852 761 Mic 5	Mic 5	5	47600
	77774409	852 761 Mic 10	Mic 10		47600
	78375867	852 761 Sm-N 2	Sm-N 2		32000
	77774391	852 761 PS 3	PS 3	10	29000
	78225898	852 761 PS 6	PS 6		29000
	77774383	852 761 PS 10	PS 10		29000
	77806573	852 761 PS 25	PS 25		29000

* a wider range of element types is available on request.

8. Technical specifications

Nominal pressure:	10/25 bar (140/360 psi)
Temperature range:	-10 °C to +120 °C (other temperature ranges on request)
Bypass setting:	Δp 3.5 bar \pm 10 %
Material filter head/cover:	GAL
Material filter housing:	St
Sealing material:	NBR
Maintenance indicator setting:	Δp 2.2 bar \pm 10 %
Electrical data of maintenance indicator:	
Max. voltage:	250 V AC/200 V DC
Max. current:	1 A
Contact load:	70 W
Type of protection:	IP 65 in inserted and secured status
Contact:	normally open/closed
Cable sleeve:	M20x1.5

The switching function can be changed by turning the electric upper part by 180° (normally closed contact or normally open contact). The state on delivery is a normally closed contact. By inductivity in the direct current circuit the use of suitable protection circuit should be considered. Further maintenance indicator details and designs are available in the maintenance indicator data sheet.

We draw attention to the fact that all values indicated are average values and do not always occur in specific cases of application. Our products are continually being further developed. Values, dimensions and weights can change as a result of this. Our specialized department will be pleased to offer you advice.

We recommend you to contact us concerning applications of our filters in areas governed by the EU Directive 94/9 EC (ATEX 95). The standard version can be used for liquids based on mineral oil (corresponding to the fluids in Group 2 of Directive 97/23 EC Article 9). If you consider to use other fluids please contact us for additional support.

Housings with nominal pressure 10 bar (140 psi) are fitted standard with air bleeder valve, housings with nominal pressure 25 bar (360 psi) with a venting screw.

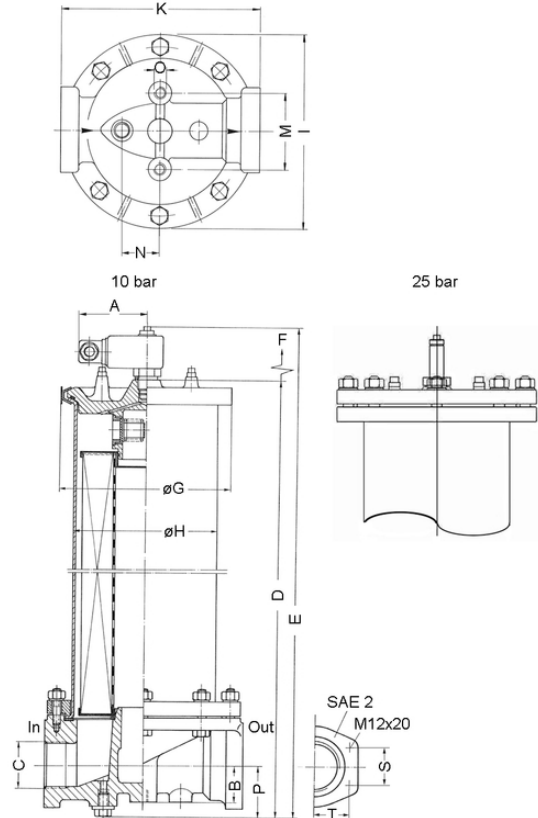

Subject to technical alteration without prior notice.

9. Dimensions

All dimensions except "C" in mm.

Type	A	B	C	D	E	F	G 10 bar	G 25 bar	H	I	K	M	N	O	P	S	T	Weight [kg]
Pi 1535	78	42	G1½	643	680	425	190	225	165	225	230	90	44	M12x20	59	-	-	17.1
Pi 1560	78	42	SAE 2	1005	1045	850	190	225	165	225	230	90	44	M12x20	59	42.9	77.8	27.1

NPT- and SAE connections on request.

* Standard pressure series hole pattern 3000 PSI

10. Installation, operating and maintenance instructions

10.1 Filter installation

When installing the filter make sure that sufficient space is available to remove filter element and filter housing.

10.2 Connecting the electrical maintenance indicator

The electrical indicator is connected via a 2-pole appliance plug according to DIN EN 175301–803 with poles marked 1 and 2. The electrical section can be inverted to change from normally open position to normally closed position or vice versa.

10.3 When should the filter element be replaced?

1. Filters equipped with visual and electrical maintenance indicator:
During cold starts, the indicator may give a warning signal. Press the red button of the visual indicator once again only after operating temperature has been reached. If the red button immediately pops up again and/or the electrical signal has not switched off after reaching operating temperature, the filter element must be replaced after the end of the shift.
2. Filters without maintenance indicator:
The filter element should be replaced after the trial run or flushing of the system. Afterwards follow instructions of the manufacturer.
3. Please always ensure that you have original MAHLE spare elements in stock: Disposable elements (PS, Sm-N, Mic) cannot be cleaned.

10.4 Element replacement

1. Stop system and relieve filter from pressure.
2. Loosen quick-action clamp (10 bar version) or screws of flanged cover, remove cover, and open drain valve. Housing completely vented.
3. Remove filter element from the filter housing.
4. Check seal for damages, replace if necessary.
5. Make sure that the order number on the spare element corresponds to the order number of the filter name-plate. Remove the plastic bag and push element over the spigot in the filter head.
6. 10 bar version: Close drain valve, relocate cover, and close the quick-action clamp. Filters are automatically vented via the air bleeder valve, the protection cap S has to be turned 2 times for being open.
7. 25 bar version: Close drain valve, and put the cover plate on so that the stud bolts go into the holes of the cover plate. Make sure not to squeeze the O-ring on the bottom side of the cover plate. Hand-tighten the 8 mounting nuts with spring rings. Then draw up the nuts tight crosswise with a turn-screw SW19 without canting the cover plate. Tightening torque for mountings nuts is 50 Nm. After bringing the hydraulic unit to service de-aerate the filter via vent-screw.

11. Spare parts list

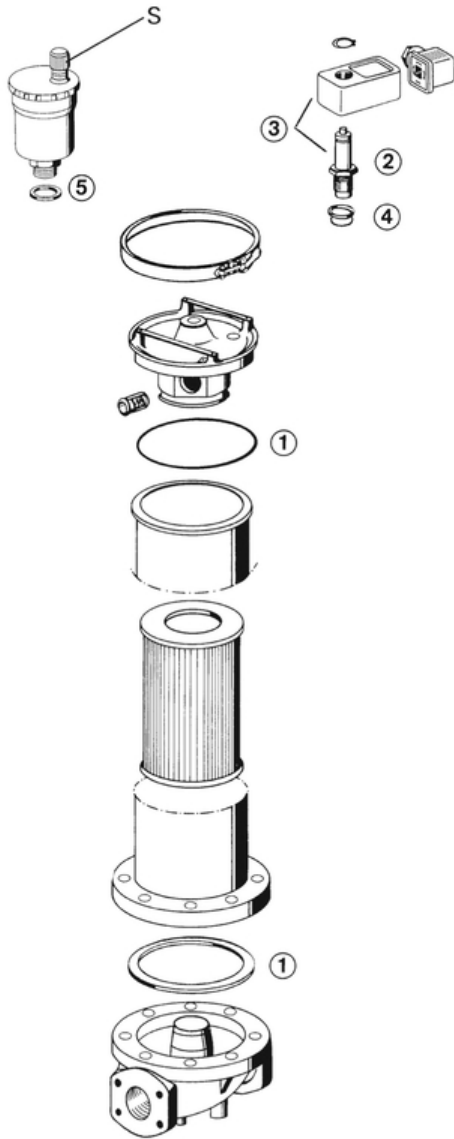

Order numbers for spare parts		
Position	Type	Order number
①	Seal kit	
	NBR	77831407
	FPM	77831415
	EPDM	77831423
② + ③	Maintenance indicator	
	Visual PiS 3098/2.2	77669971
	Electrical PiS 3097/2.2	77669948
	Electrical upper part only	77536550
④	Seal kit for maintenance indicator PiS 3098/2.2 + PiS 3097/2.2	
	NBR	77760309
	FPM	77760317
	EPDM	77760325
⑤	Air bleeder valve	70323353