

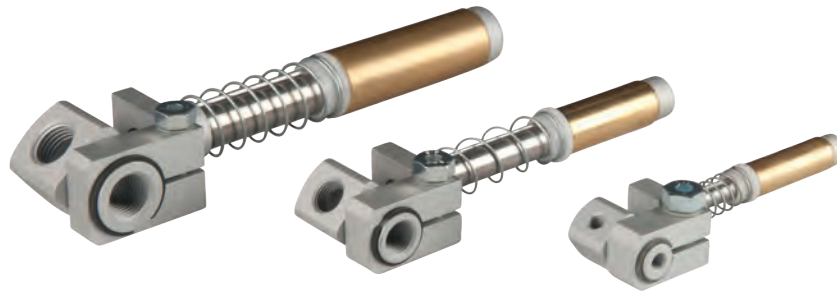

Spring compensated suction fingers for vacuum cups – non-rotating



Product notes

- > Adjustable head for mounting and aligning vacuum cups with part contours
- > Spring compensates for variation in ejection stroke
- > Smooth motion due to lubrication-free polymer bearing
- > Angle adjustment +/- 120°

Technical data

Item no.	Stroke [mm]	Weight [g]
GR03.130B	15	75

Dimensions

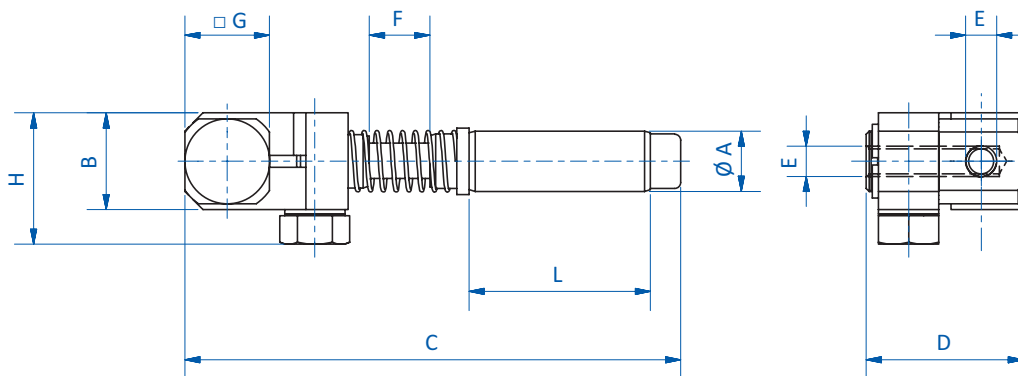

Item no.	∅ A [mm]	E	B [mm]	C [mm]	D [mm]	F [mm]	□ G [mm]	H [mm]	L [mm]
GR03.130B	14	G1/8	19	104.5	32.5	15	18	24.7	35