



### Blades for plastic, Z-shape



#### Product notes

- > Blades with offset cutting edge for overcoming obstacles or for narrow sprues
- > AH: standard blade
- > RAH: reverse cutting edge if cutting flush to workpiece with blade "AH" is not possible

#### Technical data

Item no.	Material	Max. cutting thickness [mm]		Weight [g]	Air nippers
		PP/PE	ABS		
<b>NY10RAH</b>	Ferrous alloy	3.5	2.3	40	GT-NF10 GT-NY10R GT-NY10R-4



# Nipper technology | Air nippers – stationary

Blades for plastic, Z-shape

## Dimensions

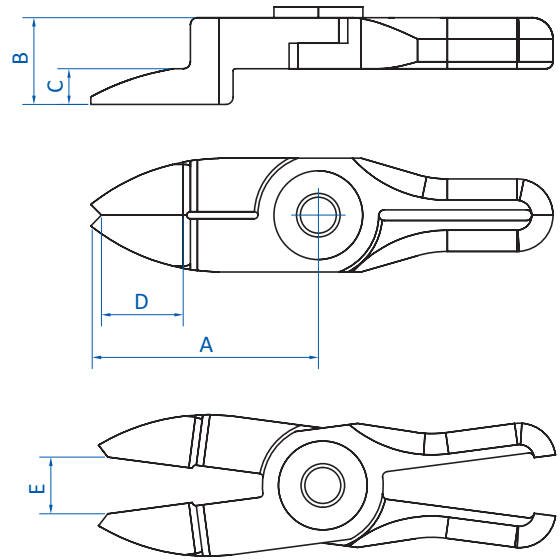

Item no.	A [mm]	B [mm]	C [mm]	D [mm]	E [mm]
NY10RAH	32	7	5	15	7