



### Vacuum regulators



#### Product notes

- > Vacuum adjustment of consumer loads, such as vacuum cups in handling systems
- > Automatic compensation of fluctuations in vacuum supply
- > Highly precise, continuous vacuum adjustment via a rotary knob with locking mechanism
- > Suitable for conducting leakage tests for inspection/measurement purposes
- > Turning the rotary knob clockwise increases the vacuum on the consumer side (SET) with the vacuum generator connected (VAC)
- > Included in scope of delivery: Vacuum gauge incl. connection adapter

#### Technical data

Item no.	Maximum flow rate [m <sup>3</sup> /h]	Regulating range [mbar (psi)]	Accuracy [mbar (inHG)]	Operating temperature [°C (°F)]	Weight [g]	Suitable vacuum gauge	Dimensions	
							G1	d1 [mm]
33.220	8.4	-999 - 0 (-14.5 - 0)	< 1.3 (0.04)	5 - 60 (41 - 140)	135	91.001-R (p.696)	--	8
33.220-G1/4	8.4	-999 - 0 (-14.5 - 0)	< 1.3 (0.04)	5 - 60 (41 - 140)	135	91.001-R (p.696)	G1/4	--
33.230	14	-999 - 0 (-14.5 - 0)	< 1.3 (0.04)	5 - 60 (41 - 140)	250	91.001-R (p.696)	--	8
33.230-G1/2	14	-999 - 0 (-14.5 - 0)	< 1.3 (0.04)	5 - 60 (41 - 140)	250	91.001-R (p.696)	G1/2	--
33.230-G1/4	14	-999 - 0 (-14.5 - 0)	< 1.3 (0.04)	5 - 60 (41 - 140)	250	91.001-R (p.696)	G1/4	--

#### Dimensions

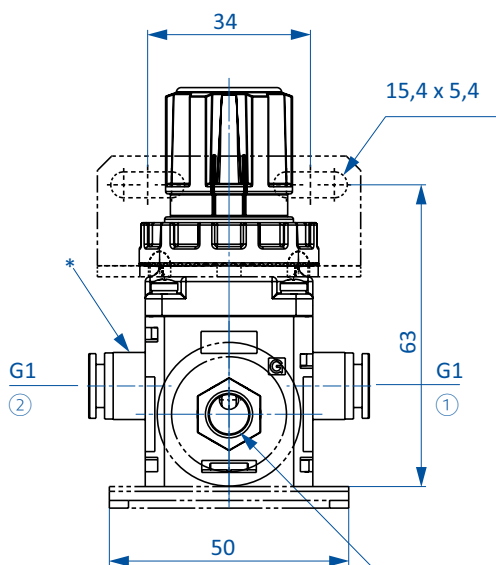

33.220 | 33.220-G1/4

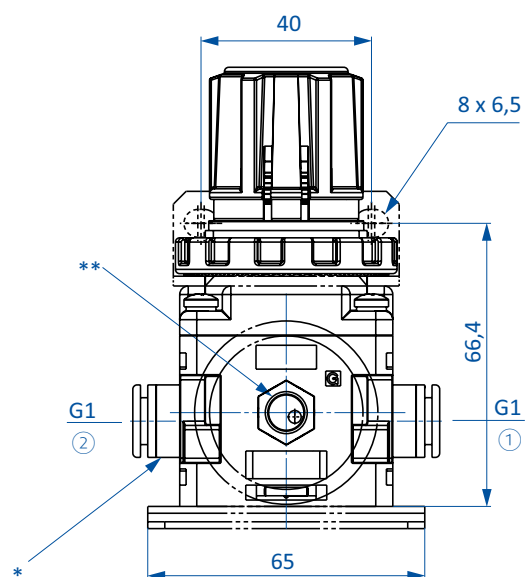

33.230 | 33.230-G1/2 | 33.230-G1/4