



# Control technology | Vacuum regulators

## Vacuum regulators with external leakage

### Vacuum regulators with external leakage

Safety control valve particularly for oil-free rotary vane pumps



#### Product notes

- > Setting a constant vacuum level when handling workpieces with varying porosities or leakage
- > Suitable as safety valve if dry-running rotary vane pumps are to run continuously at maximum vacuum
- > Control of vacuum through automatic venting when a preset vacuum level is reached
- > Manual adjustment via fine thread, mechanical opening via spring load
- > Turn the knob towards the plus (+) to increase the vacuum threshold value at which the regulator will start drawing in outside air. Turn the knob towards the minus (-) to reduce this value.
- > On request suitable as safety valve for side channel blowers to limit the max. vacuum level (diameter of regulator and blower inlet should be identical)

#### Technical data

Item no.	Maximum control volume [m <sup>3</sup> /h]	Regulating range [mbar (psi)]	Operating temperature [°C (°F)]	Weight [g]
73.003	40	-999 - 0 (-14.5 - 0)	-20 - 80 (-4 - 176)	658

#### Dimensions

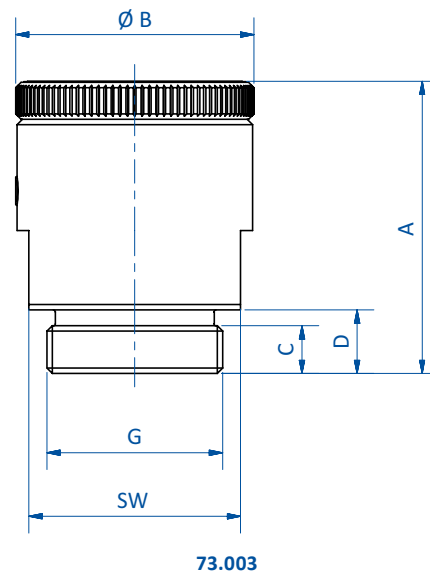

Item no.	G1	A [mm]	Ø B [mm]	C [mm]	D [mm]	SW
73.003	G1	55 - 64	45	9	12	40