

MAHLE

Driven by performance

High Pressure Filter

Pi 422

Nominal pressure 400 bar (5690 psi), nominal size up to 450
optional with reverse flow valve

1. Features

High performance filters for modern hydraulic systems

- Modular system
- Compact design
- Minimal pressure drop through optimal flow design
- Visual/electrical/electronic maintenance indicator
- Threaded or flanged connections
- Quality filters, easy to service
- Inlet sideways, outlet sideways or at the top
- Equipped with highly efficient glass fibre PS filter elements
- Beta rated elements according to ISO 16889 multipass test
- Elements with high differential pressure stability and dirt holding capacity
- NPT- and SAE-connections on request
- Worldwide distribution



3. Separation grade characteristics



y = beta-value
x = particle-size [μm]

determined by multipass tests (ISO 16889)
calibration according to ISO 11171 (NIST)

4. Filter performance data

tested according to ISO 16889 (multipass test)

PS elements with
max. Δp 20 bar

PS 3 $\beta_{5(C)} \geq 200$
PS 6 $\beta_{7(C)} \geq 200$
PS 10 $\beta_{10(C)} \geq 200$
PS 25 $\beta_{20(C)} \geq 200$

values guaranteed up to
10 bar differential pressure

PS vst elements with
max. Δp 210 bar

PS vst 3 $\beta_{5(C)} \geq 200$
PS vst 6 $\beta_{7(C)} \geq 200$
PS vst 10 $\beta_{10(C)} \geq 200$
PS vst 25 $\beta_{20(C)} \geq 200$

values guaranteed up to
20 bar differential pressure

5. Quality assurance

MAHLE filters and filter elements are produced according to the following international standards:

Norm	Designation
DIN ISO 2941	Hydraulic fluid power filter elements; verification of collapse/burst resistance
DIN ISO 2942	Hydraulic fluid power filter elements; verification of fabrication integrity
DIN ISO 2943	Hydraulic fluid power filter elements; verification of material compatibility with fluids
DIN ISO 3723	Hydraulic fluid power filter elements; method for end load test
DIN ISO 3724	Hydraulic fluid power filter elements; verification of flow fatigue characteristics
ISO 3968	Hydraulic fluid power-filters-evaluation of pressure drop versus flow characteristics
ISO 10771.1	Fatigue pressure testing of metal containing envelopes in hydraulic fluid applications
ISO 16889	Hydraulic fluid power filters-multipass method for evaluation filtration performance of a filter element

6. Symbols

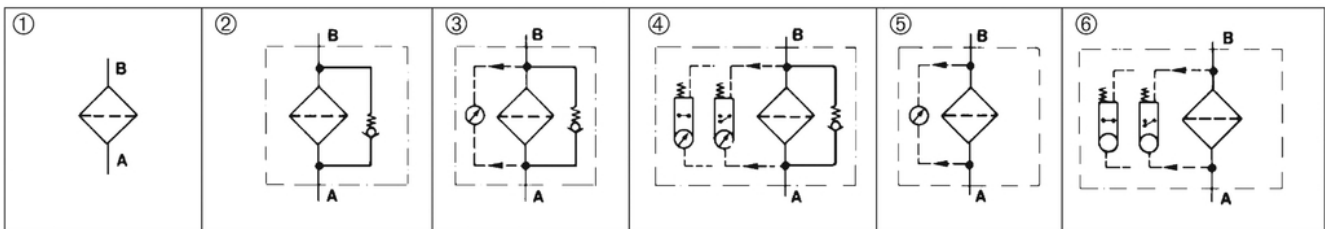

7. Type number key, housing design, order numbers

7.1 Type number key

Type	
Pi 422	High pressure filter series
	NG
	15 nominal size 150
	30 nominal size 300
	45 nominal size 450
	Connection variant 1st position
	/1 inlet and outlet sideways
	/2 inlet sideways, outlet at the top
	Connection variant 2nd position
	1 G1½
	2 flange SAE 1¼ (only for inlet sideways/outlet at the top version)
	3 flange SAE 1½
	4 G1¼ (only for inlet sideways/outlet at the top version)
	Housing design
	-010 with hole for maintenance indicator
	-011 with bypass valve and Bohrung für Wartungsanzeige
	-012 with bypass valve and visual maintenance indicator
	-013 with bypass valve and electrical maintenance indicator
	-014 with visual maintenance indicator
	-015 with electrical maintenance indicator
Pi 422	30 /1 2 -011 ordering example

7.2 Housing design

Nominal size NG [l/min]	Type		Housing design options					
	inlet sideways outlet sideways	inlet sideways outlet at the top	① with hole for indicator	② with bypass and hole for indicator	③ with bypass and visual indicator	④ with bypass and electrical indicator	⑤ with visual indicator	⑥ with electrical indicator
150	Pi 42215/1*-010	Pi 42215/2*-010						
	Pi 42215/1*-011	Pi 42215/2*-011						
	Pi 42215/1*-012	Pi 42215/2*-012						
	Pi 42215/1*-013	Pi 42215/2*-013						
	Pi 42215/1*-014	Pi 42215/2*-014						
	Pi 42215/1*-015	Pi 42215/2*-015						
300	Pi 42230/1*-010	Pi 42230/2*-010						
	Pi 42230/1*-011	Pi 42230/2*-011						
	Pi 42230/1*-012	Pi 42230/2*-012						
	Pi 42230/1*-013	Pi 42230/2*-013						
	Pi 42230/1*-014	Pi 42230/2*-014						
	Pi 42230/1*-015	Pi 42230/2*-015						
450	Pi 42245/1*-010	Pi 42245/2*-010						
	Pi 42245/1*-011	Pi 42245/2*-011						
	Pi 42245/1*-012	Pi 42245/2*-012						
	Pi 42245/1*-013	Pi 42245/2*-013						
	Pi 42245/1*-014	Pi 42245/2*-014						
	Pi 42245/1*-015	Pi 42245/2*-015						

* Connection variants see type number key 2nd position

When filter with non bypass configuration is selected, the collapse pressure of the element must not be exceeded.

7.3 Filter elements (other elements on request)

Nominal size NG [l/min]	Order number	Type designation	Filter material	Max. Δp [bar]	Filter surface [cm ²]
150	77680168	Pi 2115 PS 3	PS 3	20	2425
	77955099	Pi 5115 PS 6	PS 6		2425
	77680358	Pi 3115 PS 10	PS 10		2425
	77680473	Pi 4115 PS 25	PS 25		2425
	77680226	Pi 2215 PS vst 3	PS vst 3	210	2010
	77955123	Pi 5215 PS vst 6	PS vst 6		2010
	77680408	Pi 3215 PS vst 10	PS vst 10		2010
	77680531	Pi 4215 PS vst 25	PS vst 25		2010
300	77680176	Pi 2130 PS 3	PS 3	20	4620
	77955107	Pi 5130 PS 6	PS 6		4620
	77680366	Pi 3130 PS 10	PS 10		4620
	77680481	Pi 4130 PS 25	PS 25		4620
	77680234	Pi 2230 PS vst 3	PS vst 3	210	3800
	77955131	Pi 5230 PS vst 6	PS vst 6		3800
	77680416	Pi 3230 PS vst 10	PS vst 10		3800
	77680549	Pi 4230 PS vst 25	PS vst 25		3800
450	77680184	Pi 2145 PS 3	PS 3	20	6865
	77955115	Pi 5145 PS 6	PS 6		6865
	77680374	Pi 3145 PS 10	PS 10		6865
	77680499	Pi 4145 PS 25	PS 25		6865
	77680242	Pi 2245 PS vst 3	PS vst 3	210	5600
	77955149	Pi 5245 PS vst 6	PS vst 6		5600
	77680424	Pi 3245 PS vst 10	PS vst 10		5600
	77680556	Pi 4245 PS vst 25	PS vst 25		5600

8. Technical specifications

Design:	in-line filter inlet sideways; outlet optional sideways or on the top
Nominal pressure:	400 bar (5690 psi)
Test pressure:	520 bar (7400 psi)
Temperature range:	-10 °C to +120 °C (other temperature ranges on request)
Bypass setting:	Δp 7 bar \pm 10 %
Filter head material:	GGG
Filter housing material:	St
Sealing material:	NBR/PTFE
Maintenance indicator setting:	Δp 5 bar \pm 10 %
Electrical data of maintenance indicator:	
Maximum voltage:	250 V AC/200 V DC
Maximum current:	1 A
Contact load:	70 W
Type of protection:	IP 65 in inserted and secured status
Contact:	normally open/closed
Cable sleeve:	M20x1.5

The switching function can be changed by turning the electric upper part by 180° (normally closed contact or normally open contact). The state on delivery is a normally closed contact. By inductivity in the direct current circuit the use of suitable protection circuit should be considered. Further maintenance indicator details and designs are available in the maintenance indicator data sheet.

We draw attention to the fact that all values indicated are average values and not not always occur in specific cases of application. Our products are continually being further developed. Values, dimensions and weights can change as a result of this. Our specialized department will be pleased to offer you advice.

We recommend to contact us concerning applications of our filters in areas governed by the EU Directive 94/9 EG (ATEX 95). The standard version can be used for liquids based on mineral oil (corresponding to the fluids in Group 2 of Directive 97/23 EG Article 9). If you consider to use other fluids please contact us for additional support.

Subject to technical alteration without prior notice.

9. Dimensions

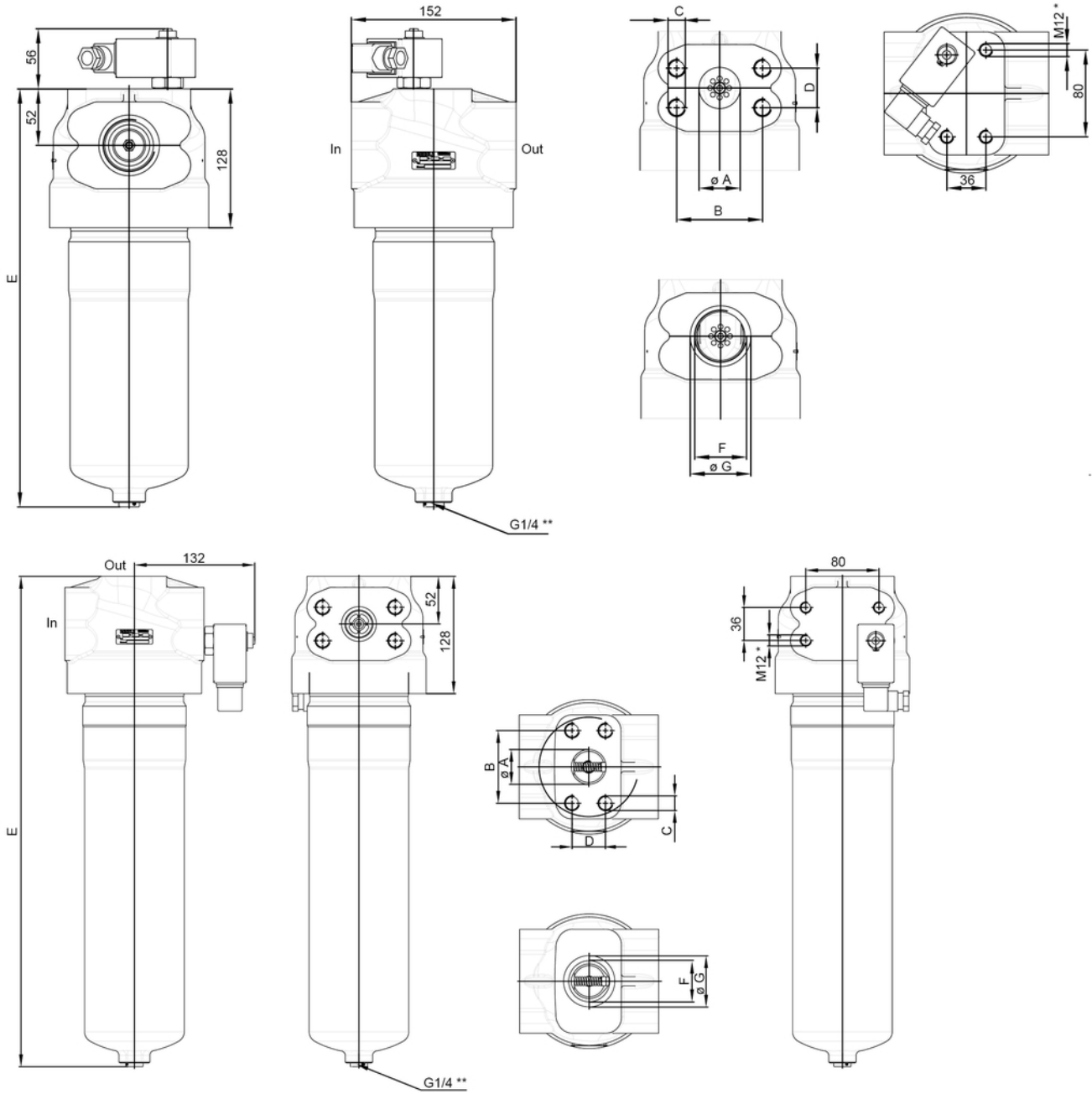

In = Inlet

Out = Outlet

* Thread depth 17 mm

** NG 150 without drain screw

All dimensions except "NG" in mm.

Type	NG	E
Pi 42215/...	150	281
Pi 42230/...	300	399
Pi 42245/...	450	515

All dimensions except "F" in mm.

Con- nection	ø A	B	C	D	F	ø G
G1¼ *	-	-	-	-	1¼"	56
G1½	-	-	-	-	1½"	56
SAE1¼ *	32	66,6	M12	31,8	-	-
SAE1½	38	79,3	M16	36,8	-	-

* only for inlet sideways/outlet at the top version

10. Execution with reverse flow valve

Filters are normally designed for single-direction flow only. Reverse flows result in destruction of the cartridge. Some applications can require the medium to flow through the filter in both directions, however. The Pi 422 with a reverse flow valve can be used here. It allows medium flows in both directions, although it only filters in one. The liquid is not filtered in reverse mode. The reverse flow valve can be supplied with or without a bypass function.

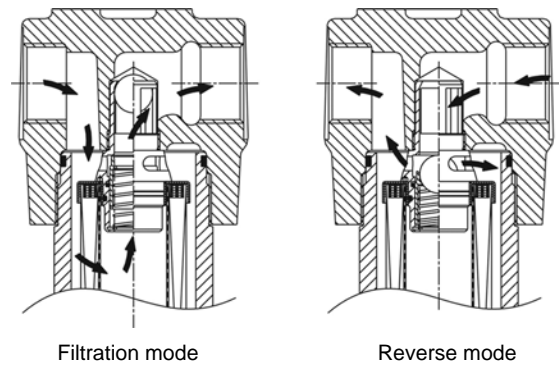

11. Installation, operating and maintenance instructions

11.1 Filter installation

When installing the filter make sure that sufficient space is available to remove filter element and filter housing. Preferably the filter should be installed with the filter housing pointing downwards.

The maintenance indicator must be visible.

11.2 Connecting the electrical maintenance indicator

The electrical indicator is connected via a 2-pole appliance plug according to DIN EN 175301-803 with poles marked 1 and 2. The electrical section can be inverted to change from normally open position to normally closed position or vice versa.

11.3 When should the filter element be replaced?

1. Filters equipped with visual and electrical maintenance indicator: During cold starts, the indicator may give a warning signal. Press the red button of the visual indicator once again only after operating temperature has been reached. If the red button immediately pops up again and/or the electrical signal has not switched off after reaching operating temperature, the filter element must be replaced after the end of the shift.
2. Filters without maintenance indicator: The filter element should be replaced after the trial run or flushing of the system. Afterwards follow instructions of the manufacturer.
3. Please always ensure that you have original MAHLE spare elements in stock: Disposable elements (PS) cannot be cleaned.

11.4 Element replacement

1. Stop system and relieve filter from pressure.
2. Filter sizes 300 and 450: empty the filter housing by removing the drain plug.
3. Unscrew the filter housing by turning counter-clockwise. Clean the housing using a suitable cleaning solvent.
4. Remove element by pulling down carefully.
5. Check o-ring, spigot and o-ring in the element locator for damage. Replace, if necessary.
6. Make sure that the order number on the spare element corresponds to the order number of the filter name-plate. To ensure no contamination occurs during the exchange of the element first open the plastic bag and push the element over the spigot in the filter head. Now remove plastic bag.
7. Oil the threads of the filter housing a little bit and screw into the filter head. Maximum tightening torque for NG 150 to 450 = 100 Nm.
8. Check seals of vent drain plug - if necessary, please replace. Torque drain plug 30 Nm.

12. Spare parts list

Order numbers for spare parts		
Position	Type	Order number
① - ③	Seal kit	
	NBR	77544885
	FPM	77544893
	EPDM	77544901
④	Maintenance indicator	
	Visual PiS 3093/5	77669914
	Electrical PiS 3092/5	77669864
	Electrical upper section only	77536550
⑤	Seal kit for maintenance indicator	
	NBR	77760275
	FPM	77760283
	EPDM	77760291

